

## MODEL MDMV - MINIATURE DISPLAY MODULE D.C. VOLTMETER



- LCD, POSITIVE REFLECTIVE OR NEGATIVE TRANSMISSIVE WITH YELLOW/GREEN OR RED BACKLIGHTING
- 1 pA INPUT LEAKAGE CURRENT TYPICAL
- 200 mV FULL SCALE
- AUTOMATIC ZEROING CIRCUIT
- SELECTABLE DECIMAL POINTS
- POLARITY INDICATION
- 5 VDC POWERED
- FIVE SELECTABLE DISPLAY ANNUNCIATORS
- PANEL MOUNT OR PC BOARD MOUNT

### DESCRIPTION

The MDMV is a small panel or printed circuit board mount digital voltmeter. With advantages of accuracy, size, and ease of installation, it is an ideal replacement for analog meters. The unit has a 3½-digit LCD display with 0.4" (10.2 mm) high digits. The displays are available in positive image reflective (black digits, reflective background) or negative image transmissive (illuminated digits, dark background) with red or yellow/green backlighting.

The integrated circuit is bonded directly to the printed circuit board and is mechanically protected. Internal electrical interface connections use elastomeric connectors to provide a corrosion resistant connection. This reliable construction also reduces the space requirements.

The MDMV module is designed to operate from a +5 VDC supply. The module measures input voltages from 0 to ±199.9 mV DC relative to the supply common.

Auto-zeroing is provided by the module, therefore no zero adjustment is required. If the input signal exceeds the input range, the unit display will indicate an overrange condition.

The module has three selectable decimal point positions and five selectable annunciators (BAT, V, A, m, µ). The BAT (Battery) annunciator is used to indicate a low battery condition, while the others are used to indicate Volts and Amperes.

### SPECIFICATIONS

1. **DISPLAY:** 3½-digit, 0.4" (10.2 mm) high digits. A minus(-) sign is displayed when the voltage is negative.
2. **DECIMAL POINTS:** Selectable decimal points are activated at the rear terminal pins to allow the display to be read in tenths, hundredths or thousandths.
3. **ANNUNCIATORS:** 5 selectable annunciators, BAT, V, A, µ and m are activated at the appropriate rear terminal.
4. **POWER REQUIREMENTS:**  
**Reflective Versions:** 3 VDC to 6 VDC @ 500 µA Max.  
**Backlight Versions:** 4.8 VDC to 6 VDC @ 25 mA Max.
5. **INPUT RANGE:** 0 to ±199.9 mV DC.
6. **COMMON MODE:** ±1 V min. around common.
7. **ACCURACY:** ±(0.1% + 1 digit).
8. **RESOLUTION:** 100 µv/Count.
9. **OVERRANGE RATINGS, PROTECTION & INDICATION:**  
**Max Input Voltage:** 6 VDC Max.  
**Overrange Indication:** Overrange is indicated by a "1" displayed in the most significant digit and the blanking of the three least significant digits.
10. **READING RATE:** 2½ readings per second.
11. **RESPONSE TIME:** 1.5 seconds to settle for a step input change.
12. **INPUT LEAKAGE CURRENT:** 1 pA typical, 10 pA Max.

Note: Recommended minimum clearance (behind the panel) for mounting clip installation is 2.25" (57.2)W x 1.5" (38.1)H.

#### PANEL MOUNT UNIT

#### DIMENSIONS In inches (mm)

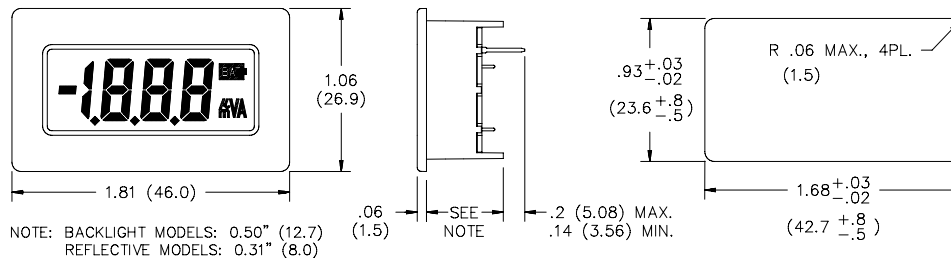

#### PANEL CUT-OUT

#### PRINTED CIRCUIT BOARD MOUNT UNIT

#### RECOMMENDED PCB LAYOUT

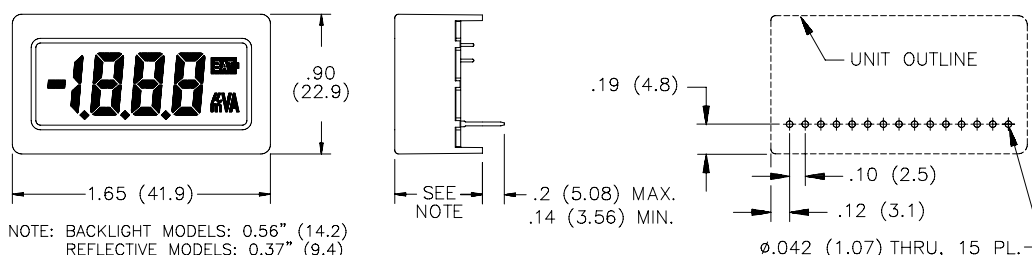

## SPECIFICATIONS (Cont'd)

13. COMMON MODE REJECTION RATIO: 70 dB.  
 14. INPUT IMPEDANCE: 1000 MΩ  
 15. TEMPERATURE EFFECTS:  
     Operating Range: 0 ° to 70 ° C  
     Storage Temperature: -40 ° to 80 ° C  
     Temperature Coefficient: 100 ppm/° C  
 16. CONSTRUCTION: High impact black plastic case. (Mounting clip included with panel mount models.)  
 17. RELATIVE HUMIDITY: Less than 85% RH.  
 18. WEIGHT:  
     Reflective Panel Mount: 0.76 oz (11 g);  
     Reflective PCB Mount: 0.54 oz (7.8 g)  
     Backlit Panel Mount: 0.96 oz (13.6 g);  
     Backlit PCB Mount: 0.75oz (10.4 g)

## INSTALLATION

The MDMV meters are available in either a panel mount or printed circuit board mount design. The panel mount units are provided with a mounting clip to securely hold the unit in the panel cutout.

### Panel mount installation:

1. Cut panel opening to specified dimensions. Remove burrs and clean panel opening.
2. Install MDMV unit through panel cutout as shown in Figure 1.
3. Slide mounting clip over rear of unit until clip is against back of panel. The unit has slots for the locking tabs to hold it in the panel opening.

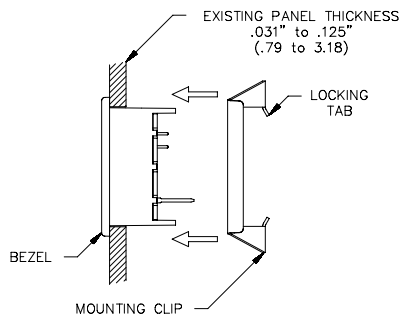

FIGURE 1

Note: Hold the MDMV front bezel in place when sliding the mounting clip in to position.

### PCB mount installation:

1. Prepare printed circuit board hole pattern to the specifications.
2. Unit should be hand soldered using good soldering techniques and hand cleaned if necessary.

## MDMV SIGNAL INPUT

The MDMV signal input range is from 0 to ±199.9 mVDC with automatic zero adjustment. Signal inputs are not floating. The calibration does not require adjustment, since the unit has been calibrated at the factory.

If the input signal exceeds 200 mV, the module will go into an overrange condition. The unit will display a minus sign when the input high terminal is negative with respect to the input low terminal.

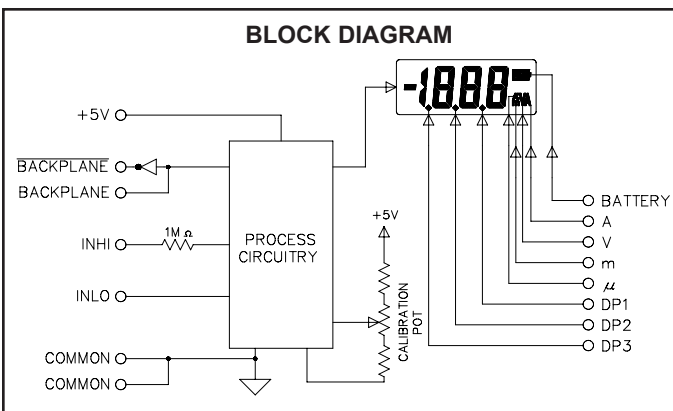

FIGURE 2

Note: Incorrect supply polarity may permanently damage the unit.

## WIRING CONNECTIONS

The electrical connections are made via terminal pins located on the back of the unit. The terminal pins are on 0.100" center lines and can be mated with the RLC Model HWK7 cable assembly or many standard 0.100" center line connectors. When wiring the unit, refer to Figure 3 to identify the wire position with the proper function.

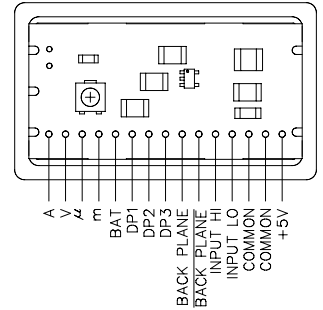

FIGURE 3

There are certain considerations that should be observed when running the signal wires. A length of wire can act like an antenna, and the closer it is to a source of electrical noise, the more it becomes susceptible to that noise.

These are a few rules that should be followed when running these wires.

1. Never run signal wires in the same conduit or raceway with A.C. power lines, conductors feeding motors, solenoids, SCR controls, heaters, etc.
2. Signal wires within enclosures should be routed as far away as possible from contactors, control relays, transformers, and other noisy components.
3. When shielded wire is used, connect the shield to the common of the MDMV unit, and leave the other end of the shield disconnected and insulated from machine ground.
4. Connect common of the MDMV to machine ground at one point only.

## PIN FUNCTIONS

+5 V	-	+5 VDC Positive Supply Terminal.
COMMON	-	Negative Supply Terminal.
COMMON	-	Negative Supply Terminal.
INPUT LO	-	Signal Input Low Terminal.
		Normally connected to Common.
INPUT HI	-	Signal Input High Terminal.
BACK PLANE	-	Back Plane Not Terminal. Any annunciator and/or decimal point will appear when its terminal is connected to this terminal.
BACK PLANE	-	Back Plane Terminal. Any annunciator and/or decimal point NOT in use must be connected to this terminal.
DP3	-	Thousandths decimal point position. *
DP2	-	Hundredths decimal point position. *
DP1	-	Tenths decimal point position. *
BAT	-	Low battery annunciator. *
m	-	Milli annunciator. *
μ	-	Micro annunciator. *
V	-	Volt annunciator. *
A	-	Ampere annunciator. *

\* Note: All annunciators must be tied to either BACK PLANE or BACK PLANE.

**HANDLING PRECAUTIONS:** This assembly contains electronic circuits that are damaged by static electricity. Before handling the assembly, discharge stray static electricity on your body by touching an earth ground point. It is also important to handle the unit by the bezel assembly only. Additionally, if it is necessary to handle a circuit board, be certain that hands are free from dirt, oil, etc., to avoid circuit contamination that may lead to malfunction.

## TYPICAL APPLICATIONS

The MDMV can be used in a wide variety of measurement applications. The following circuits show some possibilities of the exceptional versatility of the MDMV unit.

### CURRENT MEASUREMENTS

Using a shunt resistor network, the MDMV voltmeter is capable of displaying current.

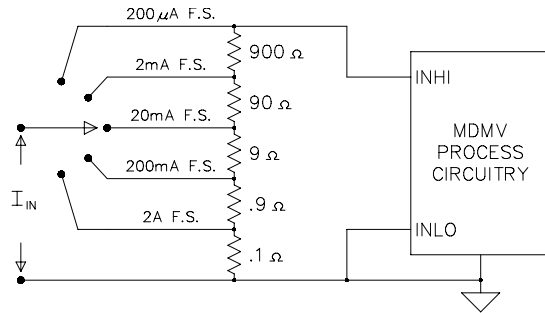

FIGURE 4

### INPUT ATTENUATORS

To measure voltages greater than 200 mVDC, a voltage divider network is needed. Shown at right is a typical circuit.

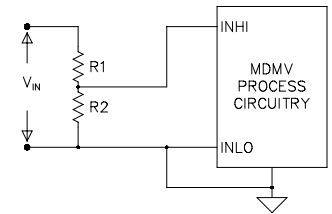

FIGURE 5

### MULTI-RANGE MEASUREMENTS

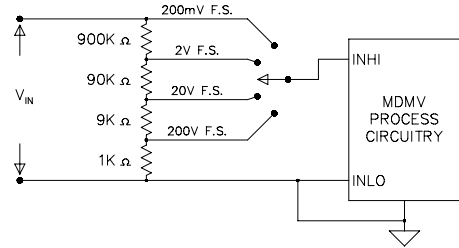

FIGURE 6

To indicate various voltages in a multi-range application, it may be necessary to switch the decimal point position and activate the appropriate annunciators. This can be accomplished by connecting the appropriate annunciator terminals, and the backplane and the backplane terminals to a multi-position rotary switch.

## ORDERING INFORMATION

MODEL NO.	DESCRIPTION	PART NUMBER
MDMV	Panel Mount W/Reflective Display	MDMV0000
	PC Board Mount W/Reflective Display	MDMV0100
	Panel Mount W/Yel-Grn Backlighting	MDMV0010
	Panel Mount W/Red Backlighting	MDMV0020
	PC Board Mount W/Yel-Grn Backlighting	MDMV0110
	PC Board Mount W/Red Backlighting	MDMV0120
HWK7	MDM Cable Assembly	HWK70000

### ACCESSORY: MDMV CABLE ASSEMBLY

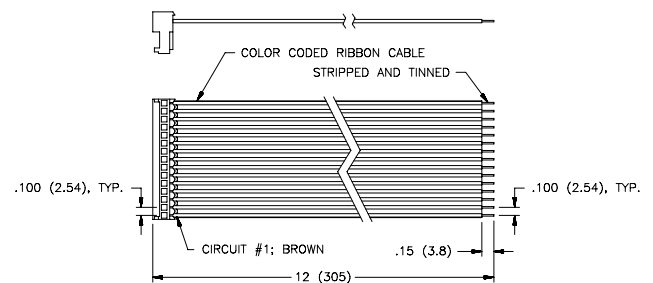

Red Lion Controls  
20 Willow Springs Circle  
York PA 17402  
Tel +1 (717) 767-6511  
Fax +1 (717) 764-0839

Red Lion Controls BV  
Basicweg 11b  
NL - 3821 BR Amersfoort  
Tel +31 (0) 334 723 225  
Fax +31 (0) 334 893 793

Red Lion Controls AP  
31, Kaki Bukit Road 3,  
#06-04/05 TechLink  
Singapore 417818  
Tel +65 6744-6613  
Fax +65 6743-3360